

SHAKING INCUBATORS

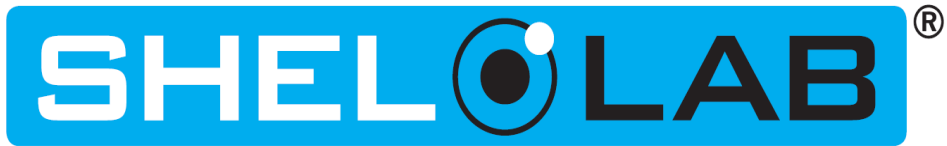

Installation - Operation Manual

SSI3 SSI3-2

The SSI3 incubator requires a 110 – 120-volt NEMA 5-15R power outlet.

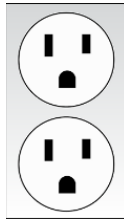

The SSI3-2 incubator requires a 220 – 240-volt CEE 7/7 power outlet.

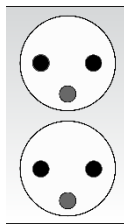

Warning: This product contains chemicals, including triglycidyl isocyanurate, known to the State of California to cause cancer as well as birth defects or other reproductive harm. For more information, go to www.P65Warnings.ca.gov.



¡Advertencia! Este producto contiene sustancias químicas, incluido el triglicidil isocianurato, que el estado de California sabe que causa cáncer, así como defectos de nacimiento u otros daños reproductivos. Para obtener más información, visite www.P65Warnings.ca.gov.

Avertissement! Ce produit peut vous exposer à des produits chimiques, dont l'isocyanurate de triglycidyle, reconnu par l'État de Californie pour provoquer le cancer, des anomalies congénitales ou d'autres problèmes de reproduction. Pour plus d'informations, visitez le site www.P65Warnings.ca.gov.

SSI Shaking Incubators

SSI3: 110 – 120 Voltage

SSI3-2: 220 – 240 Voltage

Part Number (Manual): 4861492

Revised: January 28, 2020



SHEL LAB is a brand of Sheldon Manufacturing, INC, an ISO 9001 certified manufacturer.



Safety Certifications

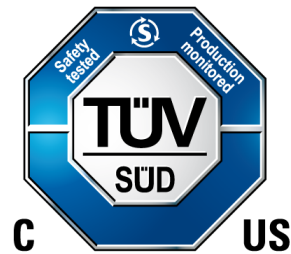

These units are CUE listed by TÜV SÜD as orbital shaking incubators for professional, industrial or educational use where the preparation or testing of materials is done at an ambient air pressure range of 22.14 – 31.3 inHg (75 – 106 kPa), and no flammable, volatile or combustible materials are being heated.

These units have been tested to the following standards:

CAN/CSA C22.2 No. 61010-1:2012
CAN/CSA C22.2 No. 61010-2-010 + R:2009
UL 61010-1:2004 + R:2005-07 + R:2008-10
UL 61010A-2-010:2002
UL 61010-1:2012
EN 61010-1:2010
EN 61010-2-010:2003

TABLE OF CONTENTS

INTRODUCTION	5
<i>Read this Manual.....</i>	5
<i>Safety Considerations and Requirements</i>	5
<i>Contacting Assistance</i>	6
<i>Manufacturing Warranty</i>	6
<i>Engineering Improvements.....</i>	6
<i>Required Accessories</i>	7
<i>Reference Sensor Device</i>	8
RECEIVING YOUR UNIT	9
<i>Inspect the Shipment.....</i>	9
<i>Orientation Images</i>	10
<i>Recording Data Plate Information</i>	12
INSTALLATION	13
<i>Installation Procedures Checklist</i>	13
<i>Required Ambient Conditions.....</i>	14
<i>Required Clearances.....</i>	14
<i>Power Source Requirements</i>	15
<i>Lifting and Handling</i>	16
<i>Removing from the Pallet.....</i>	16
<i>Leveling.....</i>	16
<i>Install the Incubator</i>	17
<i>Deionized and Distilled Water.....</i>	17
<i>Installation Cleaning and Disinfecting</i>	17
GRAPHIC SYMBOLS	19
CONTROL OVERVIEW	21
OPERATION.....	23
<i>Theory of Operation</i>	23
<i>Put the Incubator into Operation</i>	25
<i>Adjusting Agitation and Platform Load Capacity.....</i>	27
<i>Install Shaker Accessories.....</i>	32
<i>Set the Temperature Setpoint</i>	33
<i>Set the Shaker Speed (RPM).....</i>	34
<i>Set the Over Temperature Limit.....</i>	35
<i>Set the Timer</i>	36
<i>Loading Samples.....</i>	37
<i>Condensation and the Dew Point</i>	38
USER MAINTENANCE.....	39
<i>Cleaning and Disinfecting.....</i>	39
<i>Minimizing Contamination Exposure</i>	40
<i>Door Components.....</i>	41
<i>Electrical Components</i>	41
<i>Storing the Incubator.....</i>	41
<i>Calibrate the Temperature Display.....</i>	42
UNIT SPECIFICATIONS	47
<i>Weight.....</i>	47
<i>Dimensions.....</i>	47
<i>Capacity</i>	47
<i>Temperature</i>	48
<i>Shaking Platform</i>	48
<i>Power.....</i>	48
PARTS LIST.....	49

INTRODUCTION

Thank you for purchasing a SHEL LAB shaking incubator. We know you have many choices in today's competitive marketplace when it comes to constant temperature equipment. We appreciate you choosing ours. We stand behind our products and will be here if you need us.

READ THIS MANUAL

Failure to follow the guidelines and instructions in this user manual may create a protection impairment by disabling or interfering with the unit safety features. This can result in injury or death.

Before using the unit, read the manual in its entirety to understand how to install, operate, and maintain the unit in a safe manner. Ensure all operators are given appropriate training before the unit begins service.

Keep this manual available for use by all operators.

SAFETY CONSIDERATIONS AND REQUIREMENTS

Follow basic safety precautions, including all national laws, regulations, and local ordinances in your area regarding the use of this unit. If you have any questions about local requirements, please contact the appropriate agencies.

SOPs

Because of the range of potential applications this unit can be used for, the operator or their supervisors must draw up a site-specific standard operating procedure (SOP) covering each application and associated safety guidelines. This SOP must be written and available to all operators in a language they understand.

Intended Applications and Locations

SSI incubators are intended for constant temperature, non-humidified microbiological shaking incubation applications in professional, industrial, and educational environments. These units are not intended for use at hazardous or household locations.

Power

Your unit and its recommended accessories are designed and tested to meet strict safety requirements.

- The unit is designed to connect to a power source using the specific power cord type shipped with the unit.
- Always plug the unit power cord into a protective earth grounded electrical outlet conforming to national and local electrical codes. If the unit is not grounded properly, parts such as knobs and controls can conduct electricity and cause serious injury.
- Do not bend the power cord excessively, step on it, or place heavy objects on it.
- A damaged cord can be a shock or fire hazard. Never use a power cord if it is damaged or altered in any way.
- Use only approved accessories. Do not modify system components. Any alterations or modifications to your unit not explicitly authorized by the manufacturer can be dangerous and will void your warranty.

CONTACTING ASSISTANCE

Phone hours for Sheldon Technical Support are 6 am – 4:30 pm Pacific Coast Time (west coast of the United States, UTC -8), Monday – Friday. Please have the following information ready when calling or emailing Technical Support: the **model number**, **serial number**, and **part number** (see page 12).

support@sheldonmfg.com
+1-800-322-4897 extension 4
+1-(503) 640-3000 extension 4
FAX: +1-(503) 640-1366

Sheldon Manufacturing, INC.
P.O. Box 627
Cornelius, OR 97113
USA

MANUFACTURING WARRANTY

For information on your warranty and online warranty registration please visit:

- sheldonmanufacturing.com/warranty

ENGINEERING IMPROVEMENTS

Sheldon Manufacturing continually improves all of its products. As a result, engineering changes and improvements are made from time to time. Therefore, some changes, modifications, and improvements may not be covered in this manual. If your unit's operating characteristics or appearance differs from those described in this manual, please contact your SHEL LAB dealer or customer service representative for assistance.

INTRODUCTION

REQUIRED ACCESSORIES

Flask clamps, stationary tube racks, or plate clamps are required to secure samples to the shaking platform. **Clamps and racks must be purchased separately.**

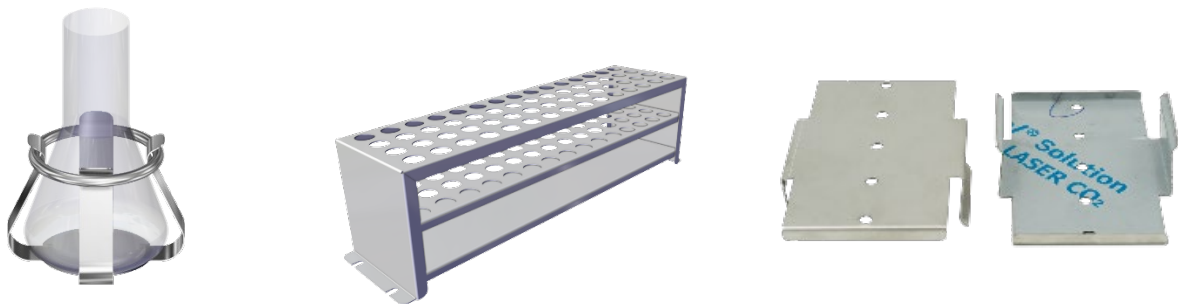

The manufacturer offers for sale several types of shaker accessories compatible with this incubator model. See page 50 for ordering information.

REFERENCE SENSOR DEVICE

Must be purchased separately

A reference sensor device is required for calibrating the unit temperature display.

Reference devices must meet the following standards:

- Accurate to at least 0.1°C

The device should be regularly calibrated, preferably by a third party.

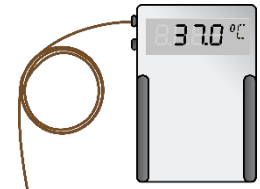

Temperature Reference

Temperature Probes

Use a digital device with wire thermocouple probes that can be introduced into the unit chamber through the lid space. Select thermocouples suitable for the application temperature you will be calibrating at.

Why Probes?

Reference readings taken outside the chamber using wire temperature probes avoid chamber lid openings. Openings disrupt the chamber temperature. Each disruption requires **a minimum 1-hour wait** to allow the atmosphere to re-stabilize before continuing.

No Alcohol or Mercury Thermometers

Alcohol thermometers do not have sufficient accuracy to conduct accurate temperature calibrations.

Never place a mercury thermometer in the unit chamber. Always use thermocouple probes.

RECEIVING YOUR UNIT

INSPECT THE SHIPMENT

- When a unit leaves the factory, safe delivery becomes the responsibility of the carrier.
- **Damage sustained during transit is not covered by the manufacturing defect warranty.**
- Save the shipping carton until you are certain that the unit and its accessories function properly.

When you receive your unit, inspect it for concealed loss or damage to its interior and exterior. If you find any damage to the unit, **follow the carrier's procedure for claiming damage or loss.**

1. Carefully inspect the shipping carton for damage.
2. Report any damage to the carrier service that delivered the unit.
3. If the carton is not damaged, open the carton and remove the contents.
4. Inspect the unit for signs of damage. Use the orientation images in this chapter as a reference.
5. The unit should come with an Installation and Operation Manual.
6. Verify that the correct number of accessory items has been included.
7. Carefully check all packaging for accessories before discarding.

Included Accessories

SSI3	Counterweights	Power Cord	Leveling Feet
	6	1	4

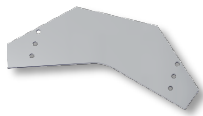

SSI3-2	Counterweights	Power Cord	Leveling Feet
	6	1	4

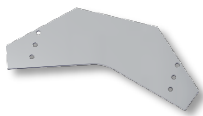

RECEIVING

ORIENTATION IMAGES

SSI3 & SSI3-2



Back of Units

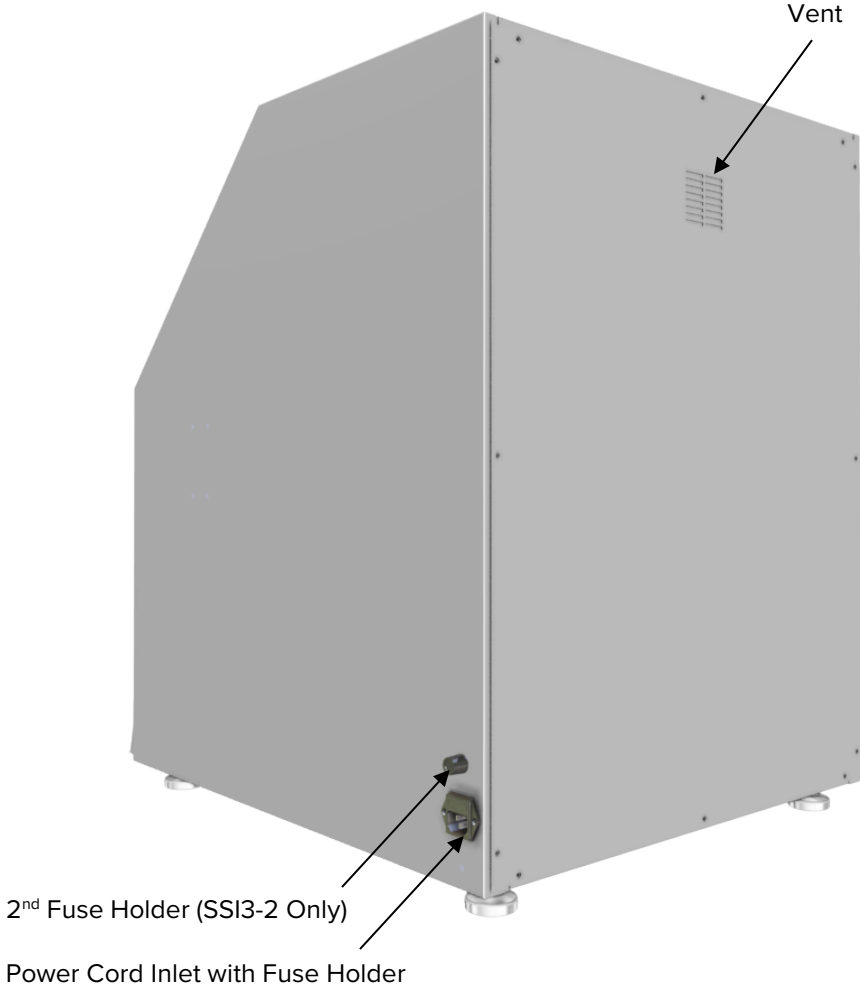

RECORDING DATA PLATE INFORMATION

Record the unit **model number**, **serial number**, and **part number** below for future reference. Tech Support needs this information to provide accurate help during support calls and emails.

- The data plate is located on the lower, right side of the unit, above the power inlet.

MODEL NO:	
SERIAL NO:	
PART NO:	

INSTALLATION PROCEDURES CHECKLIST

For installing the unit in a new workspace location.

Pre-Installation

- ✓ Check that the required ambient conditions for the unit are met, page 14.
- ✓ Check that the spacing clearance requirements are met, page 14.
 - Unit dimensions may be found on page 47.
- ✓ Check that a suitable electrical outlet and power supply is present, page 15.

Install the incubator in a suitable workspace location

- ✓ Review the lifting and handling instructions, page 16.
- ✓ Remove the unit from the pallet, page 16.
- ✓ Install the unit leveling feet, page 16.
- ✓ Install the unit in its workspace location, page 17.

Set up the incubator for use

- ✓ Clean and disinfect the unit (recommended), page 17.

INSTALLATION

REQUIRED AMBIENT CONDITIONS

These units are intended for use indoors at room temperatures between **15°C and 30°C (59°F and 86°F)**, at no greater than **80% Relative Humidity** (at 25°C / 77°F). Operating outside these conditions may adversely affect the unit temperature performance.

When selecting a location to install the unit, consider all environmental conditions that can adversely impact its temperature performance. These include:

- Proximity to ovens, autoclaves, and any device that produces significant radiant heat
- Heating and cooling vents or other sources of fast-moving air currents
- High-traffic areas
- Direct sunlight

REQUIRED CLEARANCES

These clearances are required to provide airflows for ventilation and cooling.

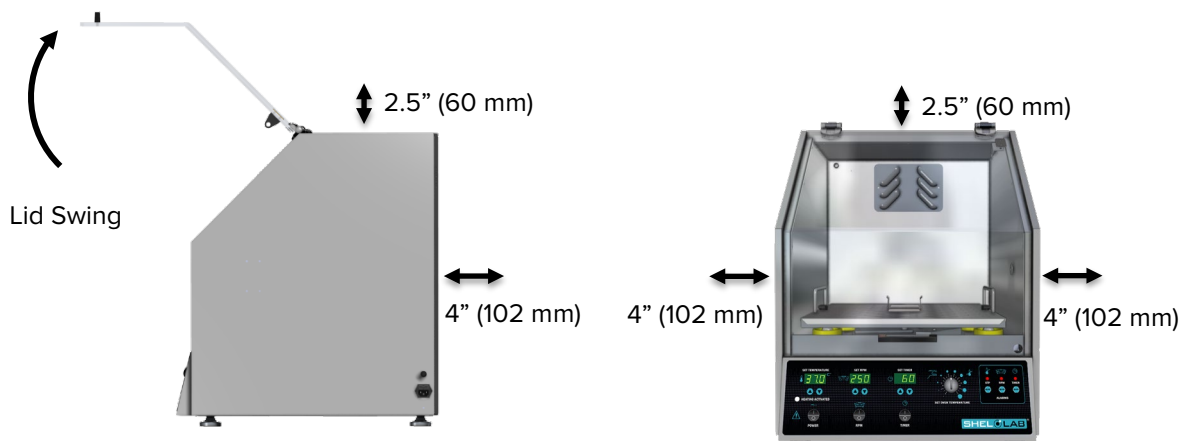

4 inches (102 mm) of clearance is required on the sides and back.

2.5 inches (60 mm) of headspace clearance is required between the top of the unit and any overhead partitions.

Ensure that there is sufficient overhead clearance for end-users to fully open the lid.

INSTALLATION

POWER SOURCE REQUIREMENTS

When selecting a location for the unit, verify each of the following requirements is satisfied:

Power Source: The power source must match the voltage and amperage requirements listed on the unit data plate. These units are intended for **50/60 Hz** applications at the following voltages and amperages:

Model	Voltage	Amperage
SSI3	110 – 120	7.0
SSI3-2	220 – 240	3.5

- The wall power source must be protective earth grounded and single phase.
- **The unit may be damaged if the supplied voltage varies by more than 10% from the data plate rating.**
- Use a separate circuit to prevent loss of the unit due to overloading or circuit failure.
- **The recommended wall circuit breaker for 110 – 120V units is 15 amps.**
- **The recommended wall circuit breaker for 220 – 240V units is 20 amps.**
- The wall power source must conform to all national and local electrical codes.

Power Cords:

The unit must be positioned so that all end-users can quickly unplug the power cord in the event of an emergency.

- The SSI3 is provided with a **125 volt, 15 Amp, 9 ft 5 in (2.89 m) NEMA 5-15P** power cord.
- The SSI3-2 is provided with a **250 volt, 16 Amp, 2.5 m (8.2 ft) CEE7/7** power cord.
- Always use this cord or an identical replacement.

Fuses

Always find and fix the cause of a blown fuse before putting the unit back into operation.

SSI3: 110 – 120-volt units ship with a single fuse installed in the power cord inlet.

- The fuse must be installed and intact for the unit to operate.
- Fuse type:
 - 250V, T16A, 5x20mm

SSI3-2: 220 – 240 units ship with one fuse installed in the power cord inlet and a second fuse in a fuse holder adjacent to the inlet.

- Fuse type:
 - 250V, T6.3A, 5x20mm

110 – 120V

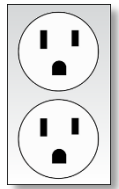

Standard NEMA 5-15R wall socket

220 – 240V

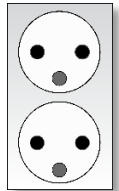

Standard CEE7/7 wall socket



INSTALLATION

LIFTING AND HANDLING

The unit is heavy. Use appropriate lifting devices sufficiently rated for these loads. Follow these guidelines when lifting the unit.

- Lift the unit only from its bottom surface.
- Doors, handles, and knobs are not adequate for lifting or stabilization.
- Restrain the unit completely while lifting or transporting so it cannot tip.
- Remove all moving parts, such as shelves and trays, and lock the door in the closed position during transfers to prevent shifting and damage.

REMOVING FROM THE PALLET

The unit comes secured to a shipping pallet with ½” hex bolts inserted through the 4 leveling feet holes on the bottom of the incubator. Use a socket wrench to remove the bolts and release the unit from the pallet.

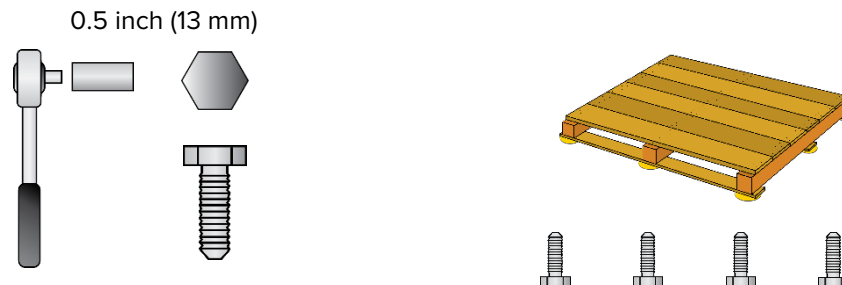

LEVELING

Install the 4 leveling feet in the 4 corner holes on the bottom of the unit. The unit must be level and stable for safe operation.

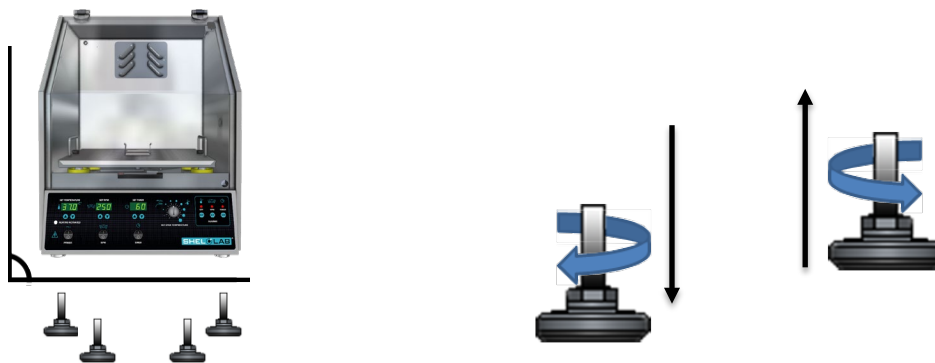

Note: To prevent damage when moving the unit, turn all 4 leveling feet so that the leg of each foot sits inside the unit.

INSTALL THE INCUBATOR

Install the unit in a workspace location that meets the criteria discussed in the previous entries of the Installation chapter.

DEIONIZED AND DISTILLED WATER

Do not use deionized water to clean the unit, even if DI water is readily available in your laboratory.

- The use of deionized water may corrode metal surfaces and **voids the manufacturing warranty**.
- The manufacturer recommends the use of distilled water in the resistance range of 50K Ohm/cm to 1M Ohm/cm, or a conductivity range of 20.0 uS/cm to 1.0 uS/cm, for cleaning applications.

INSTALLATION CLEANING AND DISINFECTING





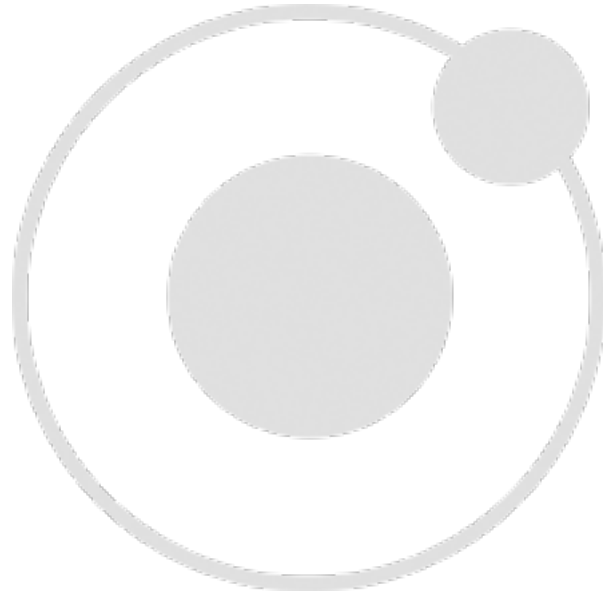



The manufacturer recommends cleaning and disinfecting the chamber prior to installing shaker accessories in the chamber.

- The unit was cleaned at the factory but may have been exposed to contaminants during shipping.
- Please see the [Cleaning and Disinfecting](#) procedure on page 39 in the User Maintenance chapter for information on how to clean and disinfect without damaging the unit.



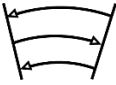

GRAPHIC SYMBOLS

The unit is provided with multiple graphic symbols on its exterior. These identify hazards and adjustable components as well as important notes in the user manual.

Symbol	Definition
	Consult the user manual Consulter le manuel d'utilisation
	AC Power Repère le courant alternatif
	I/ON O/OFF I indique que l'interrupteur est en position marche. O indique que le commutateur est en position d'arrêt.
	Timer Minuteur
	Orbital Shaking Platform Plateforme de agitateur orbital
	Adjusts UP and DOWN Ajuster le haut et vers le bas
	Temperature display Indique l'affichage de la température
	Over Temperature Limit system Thermostat température limite contrôle haute
	Manually adjustable Indique un réglage manuel

SYMBOLS

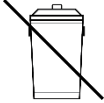
Symbol	Definition
	Protective earth ground Terre électrique
	Potential Shock Hazard Risque de choc électrique
	Recycle the unit. Do not dispose of in a landfill. Recycler l'unité. Ne jetez pas dans une décharge

CONTROL OVERVIEW

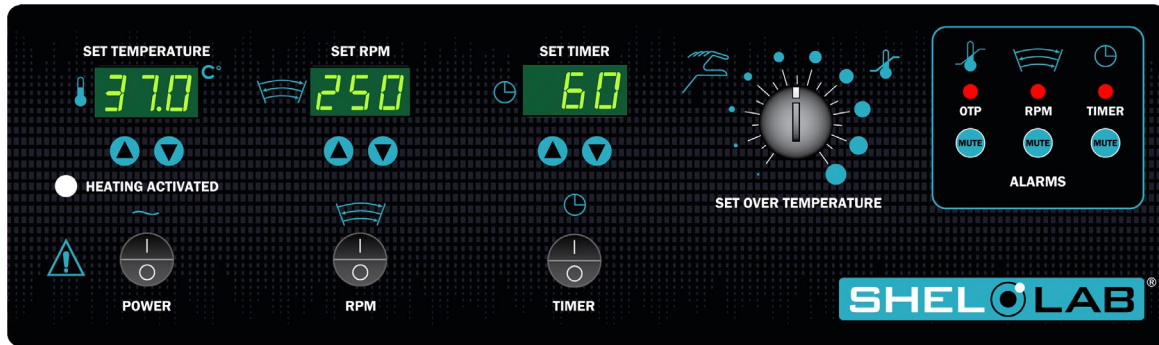

Control Panel

Main Power Switch

Power is supplied when the switch is in the (I) ON position.



Shaking Platform Power Switch (RPM)

Activates the unit shaking function when in the (I) ON position.

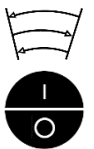

Timer Power Switch

Activates the unit timer function when in the (I) ON position.



Set Temperature Display and Controls

Shows the current chamber temperature. The **Up** and **Down** arrow buttons are used to access the Temperature Setpoint (SP) or Calibration Offset (C O) display modes and input the temperature setpoint or calibration adjustment value.

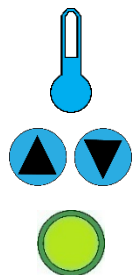

The heating activated light illuminates when the unit is calling for power to the heating elements.

Set RPM Display and Controls

Shows the current speed of the shaking platform in rotations per minute (RPM). The **Up** and **Down** arrow buttons adjust the RPM Setpoint.

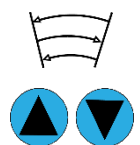

Continued next page

CONTROL

Continued from the previous page

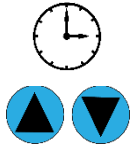

Set Timer Display and Controls

When the timer is activated, the display counts down from the current timer value. The **Up** and **Down** arrow buttons adjust the Timer value.

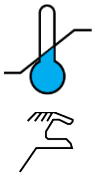

Over Temperature Limit

This graduated dial sets the mechanical heating cutoff point for the Over Temperature Limit (OTL) system. The system prevents unchecked heating of the chamber in the event of an electronics failure or external heat spike. For details, please see the [Over Temperature Limit system](#) description in the Theory of Operations (page 35).

Alarms

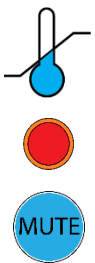

Over Temperature Alarm (OTP)

- A red light illuminates and an audible alarm sounds when the current chamber temperature exceeds the Over Temperature Limit heating cutoff point.
- Push the **MUTE** button to mute the audible alarm. The light remains illuminated until the temperature has dropped below the OTL cutoff point.

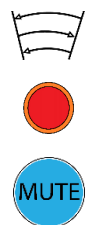

RPM Alarm

- A red light illuminates and an audible alarm sounds when the shaking platform speed deviates ± 5 RPM or more from the setpoint.
- Push the **MUTE** button to mute the audible alarm. The light remains illuminated until the RPM deviation is resolved.

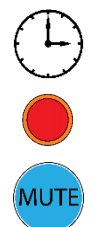

TIMER Alarm

- A red light illuminates and an audible alarm sounds when a timer countdown reaches zero.
- Push the **MUTE** button to mute the audible alarm. The light remains illuminated until the Timer switch is placed in the (O) OFF position.

THEORY OF OPERATION

Shaking Platform

The unit is equipped with an orbital shaking platform providing circular agitation to samples. The orbital shaking speed is programmed using the Set RPM controls on the front control panel.



Metal counterweights included with the incubator come installed beneath the shaking platform. The end-user can add or remove weights to accommodate varying sample loads. This stabilizes the platform during operation, preventing possible damage from excessive vibration. A severely unbalanced shaking platform may also cause the unit to move across the workspace.

The intensity of the platform agitation is controlled by adjusting the pivot point of the shaker arm and repositioning the counterweights installed beneath the platform. These adjustments change the platform orbit to create moderate or heavy agitation.

Shaking Platform Timer

The incubator timer function allows the end-user to program the shaking platform to agitate for a set amount of time. When the timer reaches zero, the platform ceases shaking.



Heating

When powered, the incubator heats to and maintains a user-selected target setpoint in the incubation chamber. The incubator senses the chamber air temperature using a solid-state probe mounted on the chamber interior wall. When the incubator detects that the chamber temperature has dropped below the target setpoint, it pulses power to the heating elements inside the chamber walls.



The incubator uses Proportional – Integral – Derivative (PID) control to avoid significantly overshooting the setpoint. This means the rate of heating slows as the chamber temperature approaches the target temperature. If the chamber temperature is above the setpoint, the incubator uses minimum heating to control the rate of cooling and avoid dipping below the setpoint.

Additionally, the PID loops optimize heating rates for the temperature environment around the incubator. If the incubator is operating in a cool room, it will increase the length of heating pulses to compensate. Likewise, when operating in a warm room the incubator uses shorter pulses. If the ambient temperature conditions change significantly, there may be minor over or undershoots as the incubator adapts.

SSI incubators rely on natural heat radiation for cooling. These units can achieve a low-end temperature just above the ambient room temperature plus the internal waste heat of the unit.

Over Temperature Limit (OTL) System



The OTL system is a user-set, mechanical heating cutoff connected to a hydrostatic sensor probe inside the incubation chamber. The system operates independently of the main microprocessor temperature controller and routes power away from the incubator heating elements if the chamber temperature exceeds the OTL temperature cutoff setting. It will continue doing so as long as the chamber temperature remains above the OTL setting. This helps safeguard the unit by preventing runaway heating in the event of electronics failures or a sudden external heat spike.

The OTL must be set by the user in order to function. The manufacturer recommends a setting of approximately 1°C above the highest temperature setpoint of your heating application. A red indicator illuminates and an audible alarm sounds when the OTL is rerouting power. Failure to set the Over Temperature Limit system voids the unit manufacturing defect warranty in the event of an overtemperature event.

PUT THE INCUBATOR INTO OPERATION

Perform the following steps and procedures to put the unit into operation after installing it in a new workspace environment.

Adjust the agitation and platform load capacity if required.

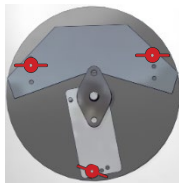

See the [Adjusting the Agitation and Platform Load Capacity](#) procedure on page 27 to configure the shaking platform the weight of your samples.

1. Install flask clamps or other required accessories.



Perform the [Install Shaker Accessories](#) procedure on page 32.

- Samples must be secured to the shaking platform using clamps, racks, or other accessories.

2. Plug in the power cord

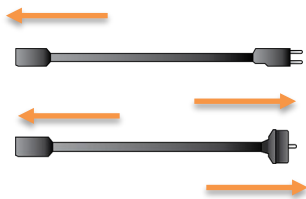

Attach the power cord that came with the unit to the power inlet receptacle on the right side of the incubator.

Plug the power cord into the workspace electrical supply outlet.

3. Turn on the incubator

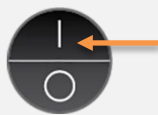

Place the incubator **Power Switch** in the ON (I) position.

4. Set an operating temperature



Perform the [Set the Temperature Setpoint](#) procedure on page 33.



Continued next page

OPERATION

Continued from the previous page

5. Allow the incubator to heat soak for a minimum of 8 hours



Wait 8 Hours

Run the unit for at least 8 hours undisturbed (for example, overnight) prior to:

- Setting the Over Temperature heating cutoff limit.
- Loading samples in the incubator



6. Set the agitation RPM rate for your application.

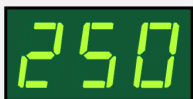

Perform the [Set the Shaker Speed](#) procedure on page 34.



7. Set the Over Temperature heating cut off limit.

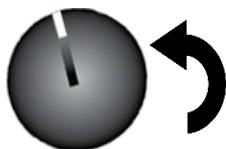

Perform the [Set the Over Temperature Limit procedure](#) on page 35.

- The incubator must be heated **and stable** at your application temperature to perform this procedure.



Optional: Set the Timer

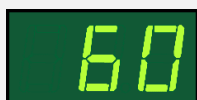

To run the shaking platform for a set amount of time, see the [Set the Timer](#) procedure on page 36.



The incubator is now ready for use.

- You may now [Load Samples](#) into the incubator, please see page 37.

OPERATION

ADJUSTING AGITATION AND PLATFORM LOAD CAPACITY

- **Adjust the Platform Agitation (Optional):** You may reposition the shaker arm pivot point **and** counterweights to change the orbital agitation intensity. The shaker arm and installed counterweights come from the factory positioned for light agitation.
- **Platform Load Capacity:** Counterweights must be added to ensure the platform is properly balanced for sample loads greater than 5 pounds.

Always turn off and disconnect the unit from its power source prior to performing this procedure.

1. Open the black latches connecting the sample tray to the platform.



2. Grasp the sample tray by the metal handles and remove it from the chamber.

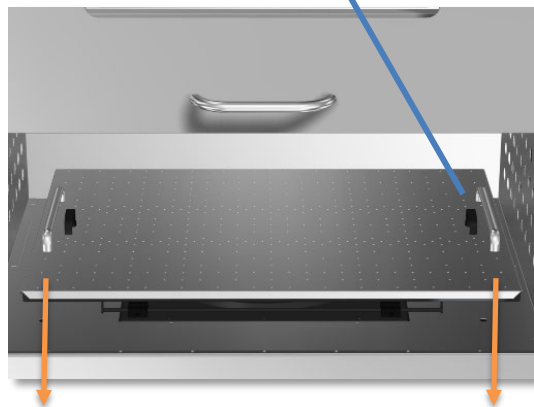

Continued next page

OPERATION

Adjusting Agitation and Platform Load Capacity, Continued



Warning: Exercise caution when rotating the shaking platform. Fingers can become pinched between the shaking platform and the metal chamber floor.

Avertissement: Soyez prudent lorsque vous faites pivoter la plateforme d'agitation. Les doigts peuvent se pincer entre la plateforme d'agitation et le plancher de la chambre métallique.

3. Manually rotate the shaking platform until the shaker arm and counterweights are visible.

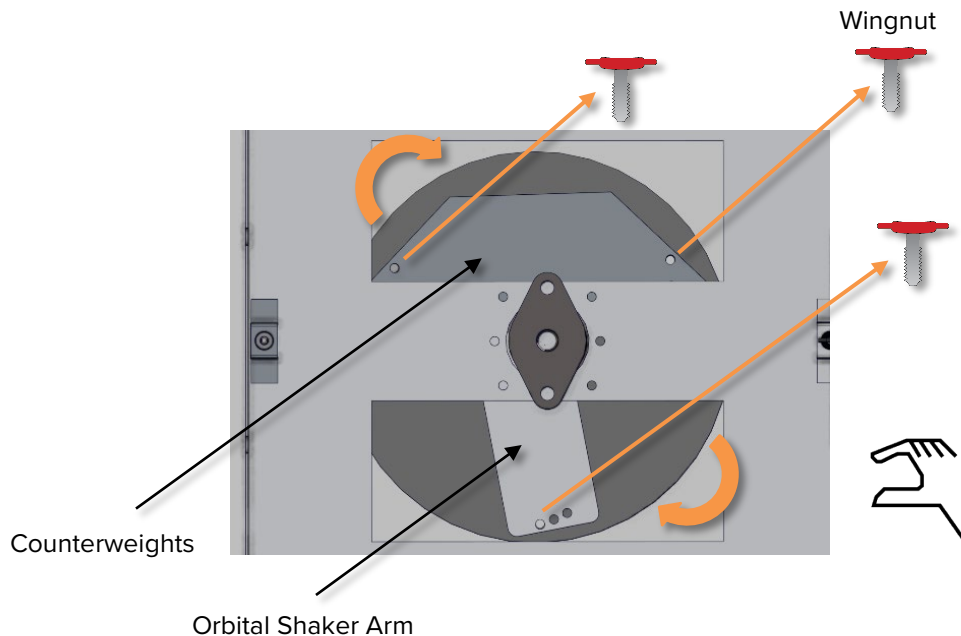

4. Remove the wingnuts from the shaker arm and the counterweights.

- If you are only adjusting the weight of the platform load, leave the wingnut attached to the orbital shaker arm.

Continued next page

OPERATION

Adjusting Agitation and Platform Load Capacity, Continued

Adjusting Platform Load Capacity

5. To properly accommodate the total platform load, adjust the number of counterweights according to the chart below. Failure to correctly balance the platform load may lead to excessive vibration.

Total Platform Load	Number of Counterweights
0 – 5 lb (2.3 kg)	2
6 – 10 lb (2.7 – 4.5 kg)	3
11 – 15 lb (4.9 – 6.8 kg)	4
16 – 20 lb (7.2 – 9.0 kg)	5
21 – 22 lb (9.5 – 10.0 kg)	6

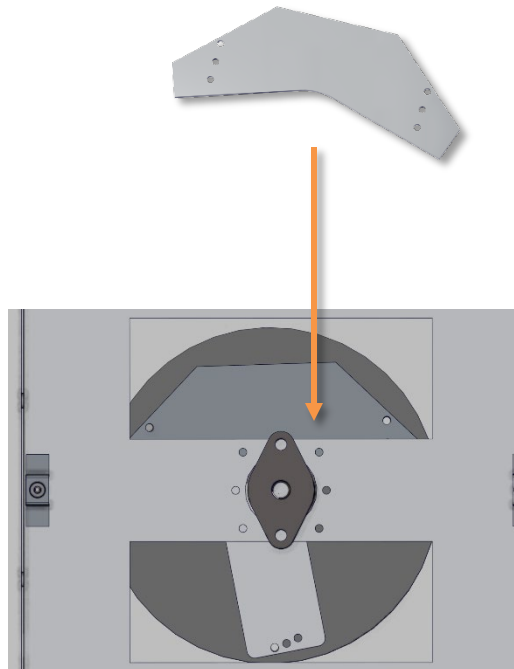

Continued next page

OPERATION

Adjusting Agitation and Platform Load Capacity, Continued

Adjust Platform Agitation

6. Reposition the counterweights **and** shaker arm to adjust the platform agitation intensity. See the diagrams below.

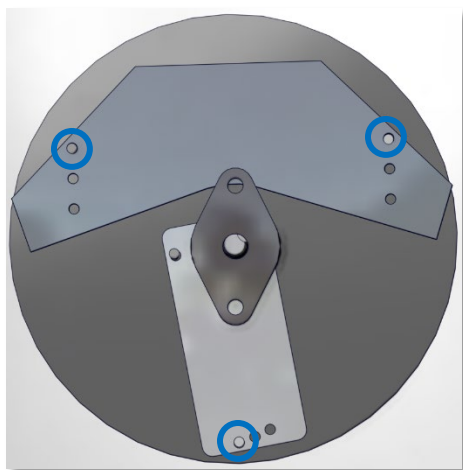

Light Agitation: 1/2" Orbit

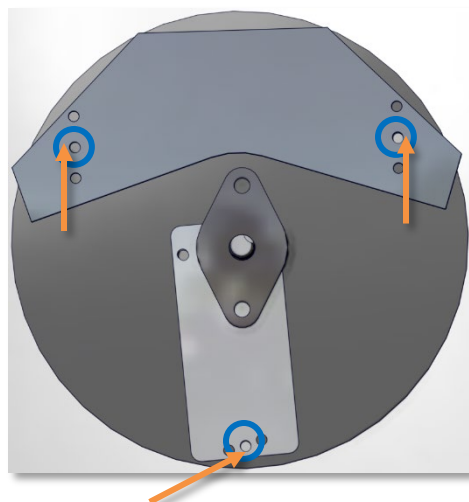

Moderate Agitation: 3/4" Orbit

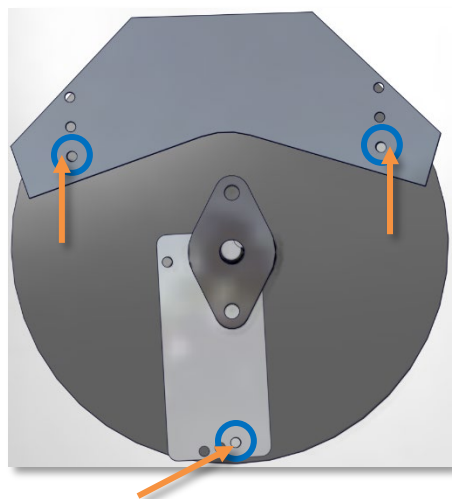

Vigorous Agitation: 1" Orbit

Continued next page

OPERATION

Adjusting Agitation and Platform Load Capacity, Continued

7. Reattach the wingnuts to the shaker arm and counterweights. **Do not tighten more than finger tight.**

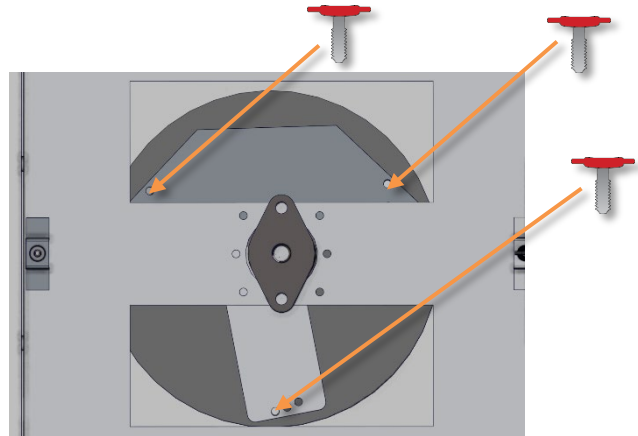

8. Place the sample tray back in the chamber.

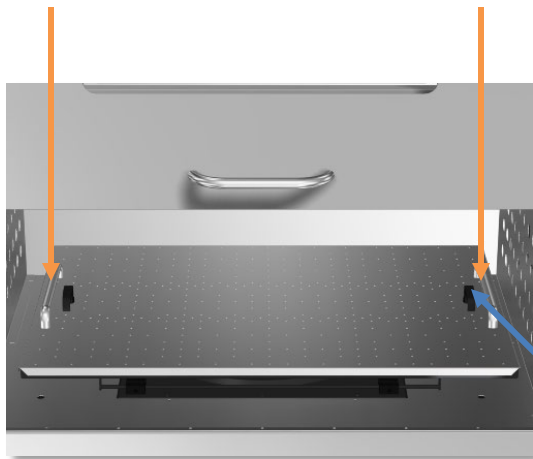

9. Close the latches, securing the sample tray to the platform.

End of Procedure

OPERATION

INSTALL SHAKER ACCESSORIES

Attach clamps, racks, or plates to the shaking platform.

1. Place clamps on the platform in your desired configuration.



2. Insert the included screws through the hole in the bottom of the clamp and into the shaking platform.

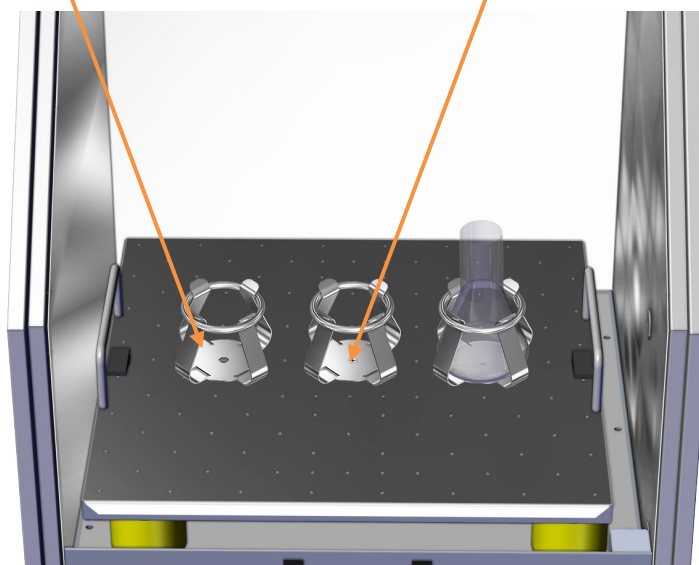

3. Use a **Phillips screwdriver** to tighten the screws until the clamp is securely fastened. Do not overtighten.

The clamps are now ready to hold sample containers. **Do not load samples at this time.**

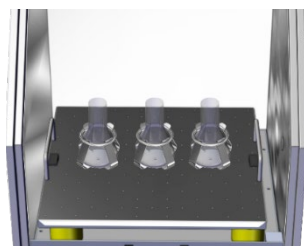

Sample Flask Clamp Layout

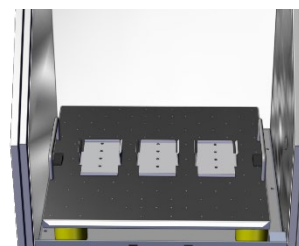

Sample Plate Holder Layout

SET THE TEMPERATURE SETPOINT



Perform the steps below to adjust the setpoint to your process or application temperature.

1. Set the Over Temperature Limit control to its maximum setting, if not already set to max

- This prevents the heating cutoff system from interfering with this procedure.

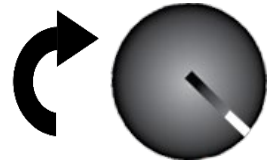

2. Navigate to the Temperature Setpoint Adjustment mode



Briefly push and release either the **Up** or **Down** arrow buttons to activate the temperature setpoint adjustment mode.

- The display will briefly flash the letters “SP”, then show the flashing, adjustable temperature setpoint.

Note: The display will automatically exit the adjustment mode after 5 seconds of inactivity, with the last shown setpoint value saved.



Setpoint Adjustment Mode

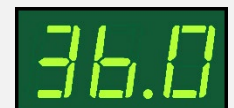

Initial Setpoint

3. Set the Temperature Setpoint



Use the **Up** and **Down** arrow buttons to change the temperature setpoint.

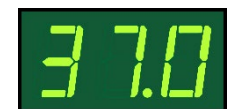

New Setpoint

4. Wait for 5 seconds after entering the Setpoint



Wait 5 Seconds

- The display will stop flashing, and the setpoint is now saved in the controller.
- The chamber will now automatically heat or passively cool to match your setpoint.
- The display will revert to showing the current chamber air temperature.

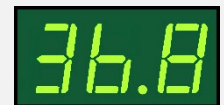

Heating to New Setpoint



End of Procedure

OPERATION



SET THE SHAKER SPEED (RPM)

Perform the steps below to adjust the RPM setpoint.

1. Turn on the shaking platform

Verify the chamber lid is completely closed.

Place the RPM switch in the (I) ON position.



- The platform will begin shaking. The platform agitates continuously as long as the RPM switch is ON.

2. Navigate to the RPM Setpoint Adjustment mode



Briefly push and release either the **Up** or **Down** arrow button to access the RPM setpoint adjustment mode.

- The display will briefly flash the letters “SP”, then show the flashing, adjustable RPM setpoint.

Note: The display will automatically exit the adjustment mode after 5 seconds of inactivity, with the last shown setpoint value saved.

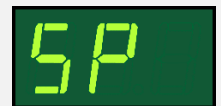

Setpoint Adjustment Mode



Initial Setpoint

3. Adjust the RPM Setpoint



Use the **Up** and **Down** arrow buttons to adjust the shaking speed to a value between 30 – 400 RPM.

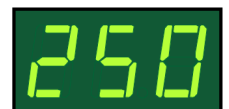

New Setpoint

4. Wait 5 seconds after entering the RPM Setpoint



Wait 5 Seconds

The display will stop flashing, and the setpoint is now saved in the controller.

- The shaking speed will now automatically increase or decrease to match your setpoint.
- The display will revert to showing the current RPM.

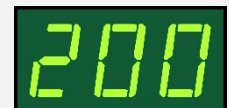

Increasing to Setpoint

End of Procedure

OPERATION

Note: Test the OTL system at least once per year to verify its functionality. **Failure to set the OTL voids the manufacturing defect warranty if over temperature damage occurs.**

SET THE OVER TEMPERATURE LIMIT

This procedure sets the mechanical heating limit cutoff to approximately 1°C above the current chamber temperature. **Perform this procedure when the unit has been running with no temperature fluctuations at your application temperature for at least 8 hours.**



1. Set OTL control dial to its maximum setting, if not already set to max

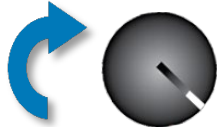

2. Turn the dial counterclockwise (to the left) until the OTL light illuminates and the audible alarm sounds



- There is a soft click when the OTL begins rerouting power away from the heating elements.

3. Slowly turn the dial clockwise (to the right) until the OTL light and audible alarm both turn off

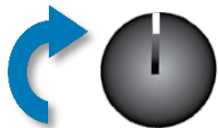

- The Over Temperature Limit is now set approximately 1°C above the current chamber air temperature.

4. Leave the OTL dial set just above the activation point



Optional: Turn the dial slightly to the left (counterclockwise)



- This sets the OTL cutoff threshold nearer to the current chamber air temperature.

If the Over Temperature Limit sporadically activates after setting the control, turn the dial very slightly to the right (clockwise). If the OTL continues activating, check for ambient sources of heat or cold that may be adversely impacting the unit temperature stability. If you find no sources of external or internal temperature fluctuations, contact Tech Support or your distributor for assistance.

End of Procedure

OPERATION



SET THE TIMER

Perform the steps below to program a timed shaking process.

1. Turn on the Timer

Verify the lid is completely closed.

Place the Timer switch in the (I) ON position.

- The platform will stop shaking until a value greater than 0 has been programmed.



2. Access the Timer Adjustment mode



Briefly push and release either the **Up** or **Down** arrow button to access the Timer adjustment mode.

- The display will briefly flash the letters “SP”, then show the flashing, adjustable timer value.

Note: The display automatically exits the adjustment mode after 5 seconds of inactivity, with the last shown timer value saved.



Timer Adjustment Mode



Initial Timer Value

3. Program the new Timer value



Use the **Up** and **Down** arrow buttons to program the desired number of minutes, up to a maximum of 999 minutes.



New Timer Value

4. Wait 5 seconds after entering the number of minutes



Wait 5 Seconds

- The display will stop flashing.
- The platform will start shaking.
- The timer will automatically begin counting down.

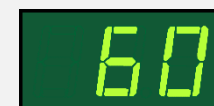

End of Countdown



TIMER



- When the countdown reaches 0, the shaking platform stops moving.
- The TIMER alarm sounds and the light illuminates.

Push the Mute button to silence the alarm.

- The TIMER light remains on until the TIMER switch is turned off.



Countdown Complete

Note: Lid openings interrupt the shaking process but will **not pause the timed countdown**. Closing the lid resumes the shaking process.

End of Procedure

LOADING SAMPLES

The manufacturer strongly recommends waiting at least **8 hours** after putting the incubator in operation before loading samples. This safeguards against temperature instability.

- Verify that sample containers are properly secured with shaker clamps or racks.
- Samples should be placed at least 1 inch (25 mm) away from the chamber walls.
 - Proper spacing allows for maximum air circulation and a higher degree of temperature uniformity.
 - Proper spacing also decreases the chance of condensate forming in the incubator when operating with a large number of samples in the chamber.



CONDENSATION AND THE DEW POINT

Relative humidity inside the incubation chamber should never be allowed to exceed 80% at 25°C.

Exceeding this threshold will likely result in condensation, possible leaks around the incubator, and may cause corrosion damage if allowed to continue for any significant length of time.

Condensation takes place whenever the humidity level in the incubation chamber reaches the dew point. The dew point is the level of humidity at which the air cannot hold more water vapor. The warmer the air, the more water vapor it can hold.

As the level of humidity rises in an incubation chamber, condensate will first appear on surfaces that are cooler than the air temperature. Near the dew point, condensate forms on any item or exposed surface even slightly cooler than the air. When the dew point is reached, condensate forms on nearly all exposed surfaces.

Managing condensation primarily depends on either lowering the humidity level or increasing the air temperature in the incubation chamber.

Note: Rising or falling air pressure from the weather will adjust the dew point up and down in small increments. If the relative humidity in the incubation chamber is already near the dew point, barometric fluctuations may push it across the dew point threshold.

Note: Thin air at higher altitudes holds less humidity than the denser air found at or near sea level.

If excessive condensate has appeared in the incubation chamber, **dry the chamber interior**. After removing the condensate, check the following:

- Ensure samples on the shaking platform are evenly spaced to allow for good airflow.
- Ensure the chamber lid is closing and latching properly.
- Are frequent or lengthy chamber lid openings causing significant temperature disruptions and chilling the chamber surfaces? If so, reduce the number of openings.
- Are there too many open or “breathable” containers of evaporating sample media in the chamber? If so, reduce the number of open sample containers.
- Does the ambient humidity in the room exceed the stated operating range of 80% relative environmental humidity? If so, lower the room humidity.
- Is the incubator exposed to an external flow of cold air such as an air-conditioning vent or a door to a cooler hallway or adjacent room? Block or divert the air or reposition the unit.
- Check the door gasket for damage, wear, or signs of brittleness or dryness. Arrange for replacement of the gasket if damaged or excessively worn.

Warning: Disconnect this unit from its power supply prior to performing maintenance or services.

Avertissement: Débranchez cet appareil de son alimentation électrique avant d'effectuer la maintenance ou les services.



CLEANING AND DISINFECTING

If a hazardous material or substance has spilled in the unit chamber, immediately initiate your site Hazardous Material Spill Containment protocol. Contact your local Site Safety Officer and follow instructions per the site policy and procedures.

- Periodic cleaning and disinfection are required.
- Do not use spray-on cleaners or disinfectants. These can leak through openings and coat electrical components.
- Consult with the manufacturer or their agent if you have any doubts about the compatibility of decontamination or cleaning agents with the parts of the equipment or with the material contained in it.
- Do not use cleaners or disinfectants that contain solvents capable of harming paint coatings or stainless steel surfaces. **Do not use chlorine-based bleaches or abrasives; these will damage the chamber liner.**

Warning: Exercise caution if cleaning the unit with alcohol or flammable cleaners. Always allow the unit to cool down to room temperature prior to cleaning and make sure all cleaning agents have evaporated or otherwise been completely removed prior to putting the unit back into service.

Avertissement: Soyez prudent lorsque vous nettoyez l'appareil avec de l'alcool ou des produits de nettoyage inflammables. Laissez toujours refroidir l'appareil à la température ambiante avant le nettoyage et assurez-vous que tous les produits de nettoyage se sont évaporés ou ont été complètement enlevés avant de remettre l'appareil en service.



Cleaning

1. Disconnect the unit from its power supply.
2. Remove all removable interior components such as shelving and accessories.
3. Clean the unit with a mild soap and water solution, including all corners.
 - **Do not use abrasive cleaners.** These will damage metal surfaces.
 - **Do not use deionized water to rinse or clean with.**
 - Take special care when cleaning around the temperature sensor probes in the chamber to prevent damage. Do not clean the probes.
4. Rinse with distilled water and wipe dry with a soft cloth.

Disinfecting

When disinfecting the unit, keep the following in mind:

- Always turn off and disconnect the unit to safeguard against electrical hazards.
- For maximum effectiveness, disinfection procedures are typically performed after cleaning.
- Disinfect the unit chamber using commercially available disinfectants that are non-corrosive, non-abrasive, and suitable for use on stainless steel and glass surfaces. Contact your local Site Safety Officer for detailed information on which disinfectants are compatible with your applications.
- If permitted by your protocol, remove all removable interior accessories (shelving and other non-attached items) from the chamber.
- Disinfect all surfaces in the chamber, making sure to thoroughly disinfect the corners. Exercise care to avoid damaging the sensor probes.
- Gas concentrations from evaporating disinfecting agents can inhibit growth or cause metabolic symptoms in microbiological sample populations. Make sure that chlorines, quaternary ammonias, or any other overtly volatile disinfecting agents have been rinsed or otherwise removed from the chamber surfaces, prior to placing samples in the chamber.

When disinfecting external surfaces, use disinfectants that will not damage painted metal, glass, and plastic.

MINIMIZING CONTAMINATION EXPOSURE

Suggestions for minimizing exposure of the incubator chamber to potential contaminants.

- Maintain a high air quality in the laboratory workspaces around the incubator.
- Avoid placing the incubator near sources of air movement such as doors, air vents, or high traffic routes in the workspace.
- Minimize the number of times the incubator lid is opened during normal operations.

DOOR COMPONENTS

Periodically, inspect the door latch, trim, catch, and gaskets for signs of deterioration. Failure to maintain the integrity of the door system shortens the life span of the unit.

ELECTRICAL COMPONENTS

Electrical components do not require maintenance. If the incubator fails to operate as specified, please contact your distributor or Technical Support for assistance.

STORING THE INCUBATOR

Perform the following steps if the incubator will be out of use for more than 24 hours to prevent microbiological contamination such as fungus or mold.

1. Depower the incubator.
2. Disinfect and clean if required by your laboratory protocol, or if the chamber has been exposed to pathogenic microorganisms.
3. Use a soft cloth to dry the chamber surfaces.

CALIBRATE THE TEMPERATURE DISPLAY

Note: Performing a temperature display calibration requires a temperature reference device. Please see the [Reference Sensor Devices](#) entry on page 8 for device requirements.

Temperature calibrations are performed to match the incubator temperature display to the actual air temperature in the incubation chamber. The actual air temperature is supplied by a calibrated reference device. Calibrations compensate for long-term drifts in the microprocessor controller as well as those caused by the natural material evolution of the sensor probe in the heated and chilled incubation space. Calibrate as often as required by your laboratory or production protocol, or regulatory compliance schedule. Always calibrate to the standards and use the calibration setup required by your industry requirements or laboratory protocol.

Suggested Calibration Setup

1. Introduce the reference device thermocouple probe through the chamber lid space.
2. Position the sensor probe head as close as possible to the geometric center of the chamber, with the probe head at least 2 inches (51 mm) from the shaking platform to prevent heatsinking, with the probe head hanging down from the chamber ceiling. **Do not attach the probe to the shaking platform.** Secure the probe head in position using the non-stick tape.
3. After securing the probe head in position, carefully close the chamber lid. Use non-stick tape to seal any gaps created by the probe wires.
4. The incubator chamber lid must be closed securely. Failure to do so will prevent an accurate calibration.

Heat-resistant, non-stick tape recommended

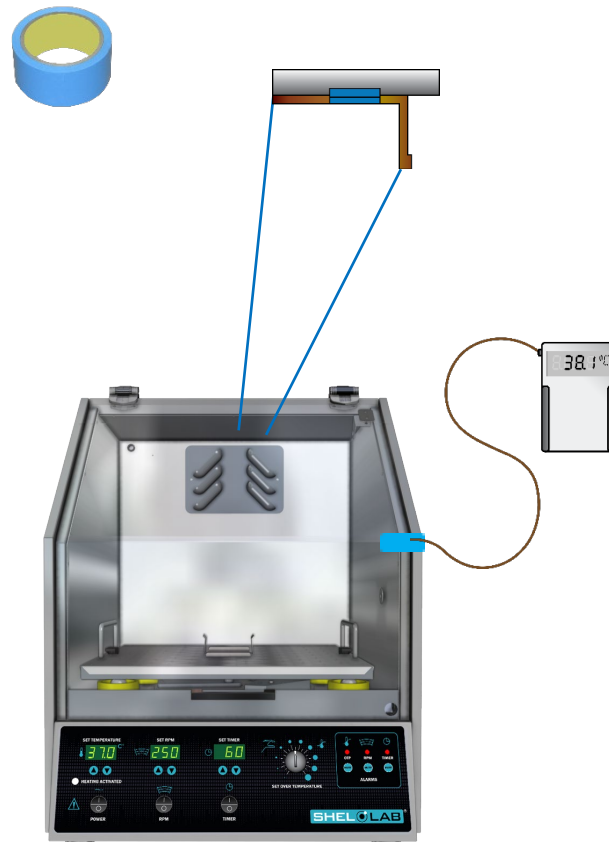

Continued next page

MAINTENANCE

5. The unit temperature must be stable in order to perform an accurate calibration.

- The incubator must run for at least 8 hours prior to conducting a calibration.
- The temperature is considered stabilized when the incubator has operated with the lid closed and the shaking platform in motion at your calibration temperature for at least 1 hour with no fluctuations greater than the specified stability of the unit (see page 48).

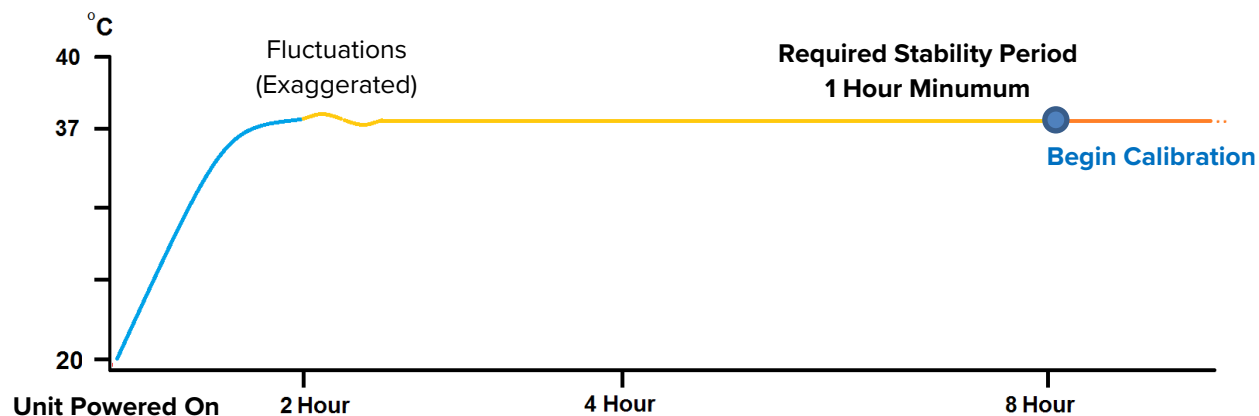

Suggested Calibration Procedure

1 Once the unit temperature has stabilized, compare the reference device and incubator temperature display readings.

- If the readings are the same, or the difference between the two falls within the acceptable range of your protocol, the display is accurately showing the temperature in the chamber. **The Temperature Calibration procedure is now complete.**

-Or-

- If the difference falls outside of your protocol range, advance to step 2.

Reference Device

37.0 °C

37.0



2

A display calibration adjustment must be entered to match the display to the reference device. See the next step.

Reference Device

38.8 °C

37.0



Continued next page

Temperature Calibration Continued

3

Place the display in its temperature calibration mode.

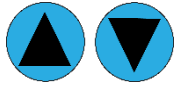

- Press and hold both the **Up** and **Down** temperature arrow buttons simultaneously for approximately 5 seconds.
- Release the buttons when the temperature display shows the letters "C O". The display will begin flashing the **current temperature display value**.



Note: The display will automatically exit calibration mode after 5 seconds of inactivity, with the last shown temperature display value saved.

4

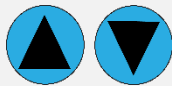

Use the **Up** and **Down** arrow buttons to adjust the current display temperature value until it matches the reference device temperature reading.

Reference Device



5



Wait 5 Seconds

After matching the display to the reference device, wait 5 seconds.

- The temperature display will cease flashing and store the corrected chamber display value.
- The incubator will now begin heating or passively cooling in order to reach the setpoint with the corrected display value.

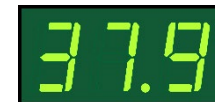

Cooling to Setpoint

6



Wait 1 Hour

Allow the incubator to operate for at least 1 hour undisturbed to stabilize **after the incubator has achieved the corrected temperature setpoint**.

- Failure to wait until the incubator is fully stabilized will result in an inaccurate reading.

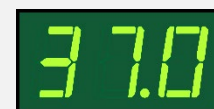

Setpoint Achieved

Continued next page

Temperature Calibration Continued

7

Compare the reference device reading with the chamber temperature display.

- If the reference device and the chamber temperature display readings are the same or the difference falls within the range of your protocol, **the incubator is now calibrated for temperature.**

-Or-

- See the next step if the readings fail to match or fall outside of your protocol range.

Reference Device



8

If the difference still falls outside the acceptable range of your protocol, repeat steps 3 – 7 up to two more times.

Reference Device

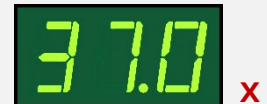
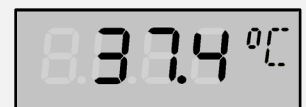

9

If the temperature readings of the incubator temperature display and the reference device still fall outside your protocol after 3 calibration attempts, contact your distributor or technical support for assistance.

End of Procedure

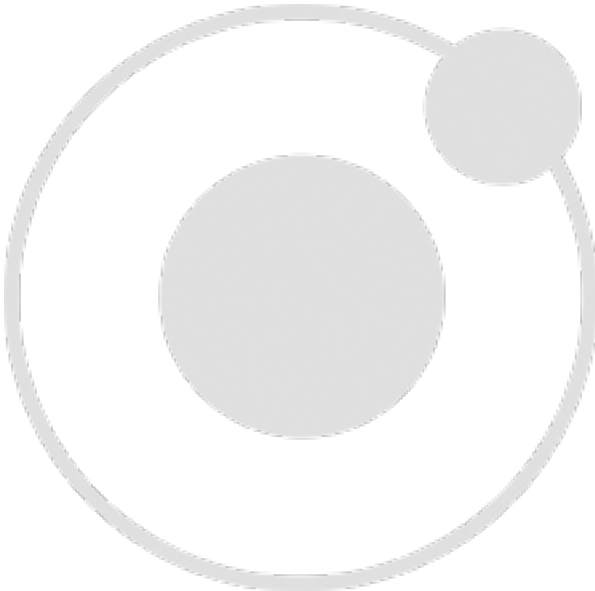

UNIT SPECIFICATIONS

SSI3 units are 110 – 120 voltage units. SSI3-2 units are 220 – 240 voltage units. Please refer to the unit data plate for individual electrical specifications.

Technical data specified applies to units with standard equipment at an ambient temperature of 25°C and at nominal voltage. The temperatures specified are determined in accordance with factory standard following DIN 12880 respecting the recommended wall clearances of 10% of the height, width, and depth of the inner chamber. All indications are average values, typical for units produced in the series. We reserve the right to alter technical specifications at all times.

WEIGHT

Model	Shipping	Net Weight
SSI3	158 lb / 73 kg	117.0 lb / 53.0 kg
SSI3-2	158 lb / 73 kg	117.0 lb / 53.0 kg

DIMENSIONS

In inches

Model	Exterior W × D × H	Interior W × D × H
SSI3	21.0 x 24.0 x 27.0 in	19.0 x 20.0 x 17.7 in
SSI3-2	21.0 x 24.0 x 27.0 in	19.0 x 20.0 x 17.7 in

In millimeters

Model	Exterior W × D × H	Interior W × D × H
SSI3	533 x 610 x 686 mm	482 x 508 x 450 mm
SSI3-2	533 x 610 x 686 mm	482 x 508 x 450 mm

CAPACITY

Volume

Model	Cubic Feet	Liters
SSI3	3.3	93.0
SSI3-2	3.3	93.0

SPECIFICATIONS

TEMPERATURE

Model	Temp Range	Uniformity	Stability
SSI3	Ambient +8°C to 60°C	±0.5°C @ 30°C	±0.1°C @ 30°C
SSI3-2	Ambient +8°C to 60°C	±0.5°C @ 30°C	±0.1°C @ 30°C





SHAKING PLATFORM

Model	RPM Range	RPM Accuracy	Max Shaker Load
SSI3	30 – 400	±4 RPM	22.0 lb / 10.0 kg
SSI3-2	30 – 400	±4 RPM	22.0 lb / 10.0 kg

POWER

Model	Voltage	Amperage	Frequency
SSI3	110 – 120	7.0	50/60 Hz
SSI3-2	220 – 240	3.5	50/60 Hz

PARTS LIST

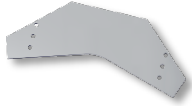
Description	Parts Number	Description	Parts Number
Adjustable Leveling Foot	 2700506	Power Cord 125 Volt, 15 Amp, 9 ft. 5 in (2.89m) NEMA 5-15P (110 – 120V unit)	 1800510
SSI3 Fuse, T16A 250V 5x20mm	 3300513	Power Cord 250 Volt, 16 Amp, 8.2 feet (2.5m), CEE7/7 (220 – 240V unit)	 1800500
SSI3-2 Fuse, T6.3A 250V 5x20mm (Requires 2 fuses)	 3300515	Counterweight, Individual (1)	 5460662

Ordering

Accessories and replacement parts can be ordered online at parts.sheldonmfg.com.

If the required item is not listed online, or if you require assistance in determining which part or accessory you need contact SHEL LAB by emailing parts@sheldonmfg.com or by calling 1-800-322-4897 ext. 4 or (503) 640-3000 ext. 4.

Please have the **model**, **serial**, and **part** numbers of the unit ready. Tech Support needs this information to match your unit to its correct part.



PARTS

Flask Clamp Accessories

Description	Parts Number	Description	Parts Number
25 ml Flask Holder	 9530528	50 ml Flask Holder	 9530529
125 ml Flask Holder	 9530530	250 ml Flask Holder	 9530531
500 ml Flask Holder	 9530526	1000 ml Flask Holder	 9530532
2000 ml Flask Holder	 9530551	2800 ml Flask Holder	 9530553
4000 ml Flask Holder	 9530554	5000 ml Flask Holder	 9530560
6000 ml Flask Holder	 9530555		

PARTS

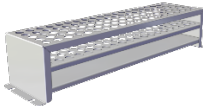
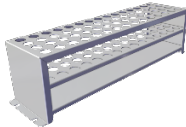
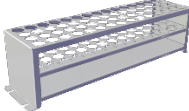
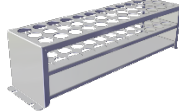
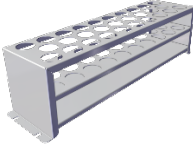
Flask Clamp Accessories, Continued

Description	Parts Number	Description	Parts Number
10 – 13 ml Test Tube Shaker Rack (100 tubes)	 9751177	14 – 16 ml Test Tube Shaker Rack (80 tubes)	 9751178
18 – 20 ml Test Tube Shaker Rack (60 tubes)	 9751179	22 – 25 ml Test Tube Shaker Rack (36 tubes)	 9751180
50 ml Test Tube Shaker Rack (29 tubes)	 9751181	Microtiter Plate Holder (96 Well)	 9900556
Flask Holder Bundle: 500 ml Flask Holder (2) 25 ml Flask Holder (10) 50 ml Flask Holder (10) 125 ml Flask Holder (5) 250 ml Flask Holder (5) 1000 ml Flask Holder (1) 2000 ml Flask Holder (1) 4000 ml Flask Holder (1)	9900687		

A large, light grey abstract graphic consisting of a large circle and a smaller circle connected by a curved line, resembling a stylized 'S' or a molecular structure, is positioned in the background of the page.

SHELDON
MANUFACTURING, INC

P.O. Box 627
Cornelius, OR 97113
USA

support@sheldonmfg.com
sheldonmanufacturing.com

1-800-322-4897
(503) 640-3000
FAX: 503 640-1366